

## The Effect of the Concrete Elimination Ratio on the Structural Behavior of Bubbled Reinforced Concrete Slabs

Yahyia Majeed Hameed\*

Department of Civil Engineering, University of Diyala, 32001 Diyala, Iraq

### ARTICLE INFO

#### Article history:

Received February 15, 2022  
Accepted March 4, 2022

#### Keywords:

Bubbled slabs  
Structural behavior  
Elimination ratio  
SCC

### ABSTRACT

This investigation focuses on the impact of the concrete elimination ratio on the structural behavior of bubbled reinforced self-compacting concrete (SCC) slabs. Construction and testing of eight bubbled slab specimens with dimensions of 45x45x80mm are part of the experimental program. The specimens are separated into two categories. The first set of four specimens is used to explore the effect of removing regular strength SCC from concrete, while the second group is used to investigate the effect of removing high strength SCC from concrete. According to the results of the experiments, increasing the number of balls in a typical strength SCC reduces the first fracture load from 8.3 % to 15.5 % and the ultimate load from 3.98 % to 12.15 %. The experimental results indicated that the change of No. of balls for high strength SCC decreases the first crack load from 2.5% to 8.92% and decreases the ultimate load from 5.95% to 16.19%. Also increase the No. of balls, it notes reduced the slab stiffness.

### 1. Introduction

The slab is an important structural part in buildings because it creates space. It is one of the largest concrete importers. The slab is designed to withstand vertical loads in general. However, as people's interest in home environments has grown in recent years, slab noise and vibration have become more important. Furthermore, as the span of a building grows longer, the deflection of slabs grows as well. As a result, slab thickness is increasing. Increased slab thickness makes the slab heavier, requiring larger columns and foundations. As a result, buildings use more materials like concrete and steel [1-3].

The concept of removing useless concrete from a slab is not a new one. Various attempts to minimize the self-weight of concrete slabs have been attempted in the past, and waffle, hollow core, and beam-block slab systems have

been and continue to be utilized to reduce the self-weight of slab buildings with long spans [4-6].

A concrete bubbled slab, on the other hand, is a type of lightweight reinforced concrete slab in which recycled industrial plastic spheres (balls) are employed to produce air holes while giving strength through arch action. These bubbles can reduce deadweight by up to 35 percent while retaining structural performance that is comparable to solid slabs of the same thickness.

Ibrahim et al [7] the flexural capacities of reinforced two-way bubble deck slabs have been investigated. To reduce self-weight, a Bubble deck slab includes a two-dimensional configuration of voids within the slabs. The ratio of bubble diameter to slab thickness affects the behavior of Bubble deck slabs. To determine the ultimate load, deflection, concrete compressive strain, and fracture pattern of the Bubble deck

\* Corresponding author.

E-mail address: [yahyia@uodiyala.edu.iq](mailto:yahyia@uodiyala.edu.iq)

DOI: [10.24237/djes.2022.15110](https://doi.org/10.24237/djes.2022.15110)

slab. The crack pattern and flexural behavior are influenced by the void diameter to slab thickness ratio, according to the results. Yasseen [8] the behavior of one-way prestressed concrete slabs containing plastic ball voids, generally known as the bubbled slab system, was investigated experimentally and theoretically. To reduce self-weight, a bubbled slab contains a two-dimensional configuration of voids. The type of specimen (solid and bubbling slabs) and the diameter of the plastic balls were the two key factors he looked at. The results showed increase in ultimate load capacity as compared with a solid slab and decrease in the deflection at service load as compared with a solid slab. Ahmed [9] the shear capacities and long-term stability of two-way hollow reinforced concrete (RC) slabs with plastic spherical gaps, also known as the bubbled RC slab system, are explored. To reduce self-weight, a two-dimensional void configuration is added in a bubbled RC slab. The strength and behavior of bubbled RC slabs with plastic spherical vacancies are investigated experimentally. An analysis of the amount of input raw materials used, energy consumption, and CO<sub>2</sub> emissions for bubbling RC slabs revealed that the quantity of input raw materials used, such as sand, gravel, and cement, was reduced by up to 28%, resulting in a reduction in the cost of these materials. Sustainable analysis proves that energy consumption and CO<sub>2</sub> emissions may be minimized. Mutashar [10] the bending behavior of sustainable reactive powder concrete (RPC) concrete roofing sheets was investigated. In this study, two types of scrapping panels were investigated: the bubble surface plate, which is made of plastic balls with a diameter set at clear distances between the balls in both directions, and the tube surface plate, which is made of plastic tubes of the same dimension and spacing. The slab type is one of the most important variables investigated (bubble, hollow core and solid plate). To determine load capacity, deflection, concrete stresses, cracking pattern, and failure patterns, data was collected at all stages of loading. The findings revealed that increasing the number of steel fibers in solid, bubble, and hollow panels lowers the deviation. As steel fibers increase, pressure reduces in

locations of intense pressure and pressure. Solid tiles have a bigger variance than bubble and hollow core tiles. Reinforced panels with both upper and lower steel mesh exhibit less deviation than those with only lower steel mesh. In comparison to hard tiles, the voids in hollow bubbles and slabs have lower weight, which is reflected in our sustainability goals. Mahmood and Dawood [11] the ultimate load carrying capacity, central deflection, and slab fracture pattern at the ultimate load were investigated in a punching shear experiment with continuous bubbling flat slabs. Harba and Hameed [12] stirrups and horizontal intermediate mesh reinforcement were tested for their efficiency in enhancing punching shear resistance and deformation capacity of the slab-column connection in bubbled slabs. ten square specimens, 1000 mm x 1000 mm in size and thickness (100mm), Type of specimen (solid or bubbled slabs), shear reinforcement ratio, type of stirrups (separated or multiple leg stirrups), number of layers for intermediate mesh (one or two layers), and position of bubbles with respect to the critical zone are the primary variables investigated (inside or outside). The usage of stirrups and intermediate mesh with bubbled slabs increased the ultimate load from 10% to 69 percent when compared to when shear reinforcement was not used. Ibrahim et al. [13] the influence of spherical shapes (spherical and elliptical) and the distance between the spheres in the cross section (25 and 70 mm) on the strength and behavior of this type of plate was investigated in an experimental investigation. Recycled plastic balls are used to make bubbles. With the same amount of concrete reduction, bubble boards with spherical balls are more efficient at transporting loads than those with oval balls, according to the results. Yaagoob and Harba [14] the shear strength behavior of a one-way bubble deck slab made of self-compacting concrete (SCC) was explored experimentally. In this experiment, two types of slabs were investigated: a bubble deck slab manufactured with plastic balls of (73, 60) mm diameter, and a normal solid slab (without balls) utilized as a reference. This study took into account a number of variables, including ball diameter (73,60) mm, shear reinforcement ratio, and ball

spacing. In general, past investigations have shown that there is a significant lack of comprehension about the influence of concrete elimination ratio on bubbled RC slabs. As a result, the purpose of this research is to determine how the concrete elimination ratio effects the structural performance of bubbled reinforced self-compacting concrete (SCC) slabs.

## 2. Program for experiment

The experimental program involves evaluating eight self-compacting concrete bubble slabs to investigate how the concrete elimination ratio influences the slabs' structural behaviour. The concrete elimination ratio for the eight slabs was changed as described in Table (1). The slabs are all the same size (450 x 450 x 80 mm) as shown in Figure (1). Figure (2) and Figure (3) distribution of reinforcement and balls.

**Table 1:** Experimental program

| No. of Group | Details about the group                    | Slab | No. of Balls |
|--------------|--|------|--------------|
| One          | Normal Strength Self – Compacting Concrete | S1   | 5 x 5        |
|              |  | S2   | 6 x 6        |
|              |  | S3   | 7 x 7        |
|              |  | S4   | 8 x 8        |
|              |  | S5   | 5 x 5        |
| Two          | High Strength Self – Compacting Concrete   | S6   | 6 x 6        |
|              |  | S7   | 7 x 7        |
|              |  | S8   | 8 x 8        |

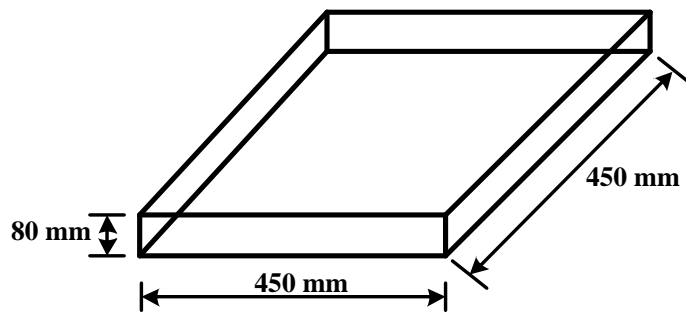

**Figure 1.** Dimensions of slab used in this study

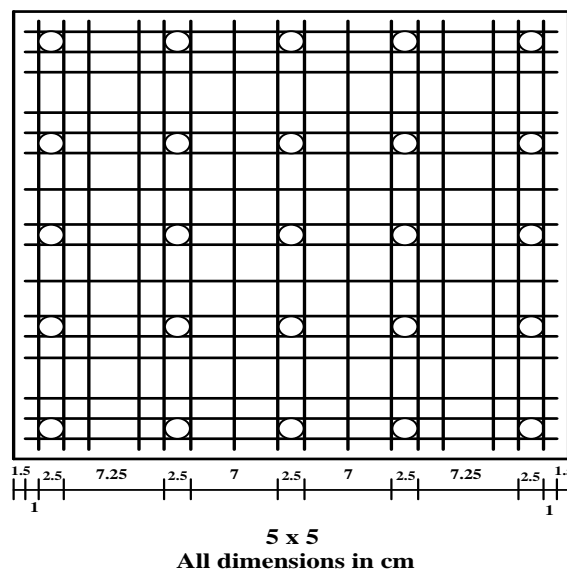

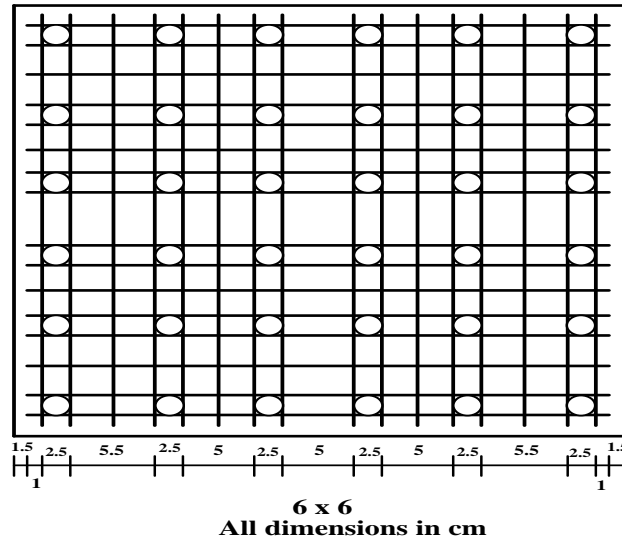

Figure 2. Distribution of reinforcement and balls for slab 5x5 and 6x6

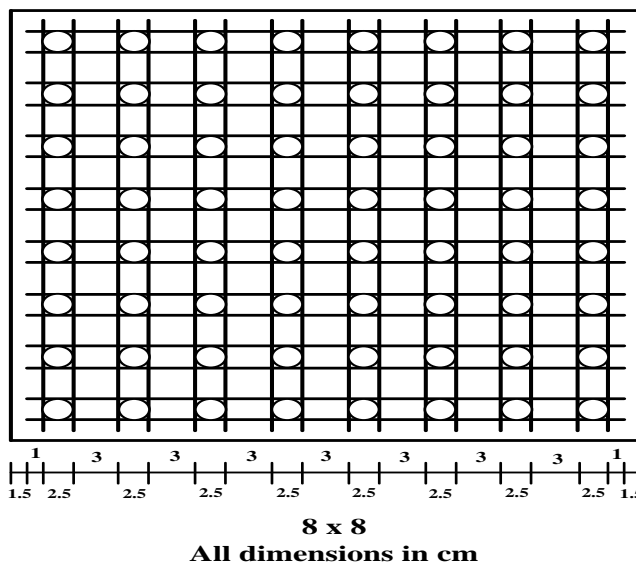
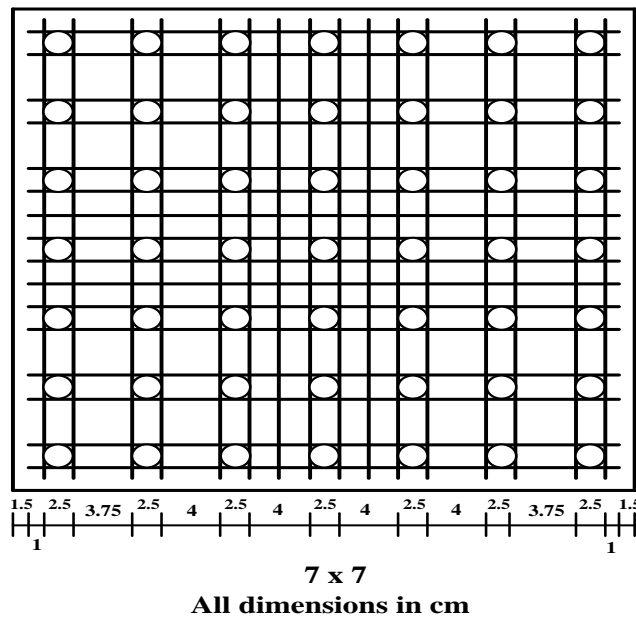

Figure 3. Distribution of reinforcement and balls for slab 7x7 and 8x8

### 3. Material components

#### 3.1. Self – compacting concrete

Cement Type I satisfies Iraqi specification No.5/1984 [15], gravel with a maximum size of 10 mm satisfies Iraqi specification No.45/1984, and sand satisfies Iraqi specification

No.45/1984 [16], limestone powder satisfies EFNARC 2002 recommendations [17], high-range water reducer satisfies ASTM C494 type A [18], and tap water is used to cast the bubbled slabs in this study. Table (2) shows the components and their proportions per cubic meter.

**Table 2:** Proportions of normal and high SCC mixes

| Mix type                                   | Cement (kg/m <sup>3</sup> ) | Limestone powder (kg/m <sup>3</sup> ) | Water (kg/m <sup>3</sup> ) | Sand (kg/m <sup>3</sup> ) | Gravel (kg/m <sup>3</sup> ) | Super plasticizer (kg/m <sup>3</sup> ) |
|--|-----------------------------|---------------------------------------|----------------------------|---------------------------|-----------------------------|--|
| Normal Strength Self – Compacting Concrete | 370                         | 200                                   | 190                        | 797                       | 767                         | 2                                      |
| High Strength Self – Compacting Concrete   | 550                         | 50                                    | 160                        | 855                       | 767                         | 15                                     |

#### 3.2. Steel reinforcement

The main steel reinforcement bars were deformed 4 mm diameter of 406 MPa yield stress was used to form the flexural reinforcement of all the slabs. The secondary reinforcement was made from steel bars with 4 mm diameter. According to (ASTM A616/A 615M, 2000) [19]. Figure (4) shows the slabs reinforcement used in this study.

#### 3.3. Balls

In this experiment, we used recycled balls to lower the weight of reinforced concrete in our laboratory. In each mold of the experiment, balls with a diameter of 40 mm were employed and put between the reinforcing steel at fixed distances, as indicated in Figure (4).



**Figure 4.** Sample of Balls

#### 4. Mixing

To complete the mixing process, a rotary mixer was used. The steps involved in SCC mixing are as follows: At the commencement of the mixing procedure, the gravel and sand were mixed for a minute and a half, then the powdered limestone and cement were added and mixed for another minute and a half. The mixing of water was lowered in the second step, and water was gradually added to the mixer. Finally, to achieve a more uniform combination, the mixing technique was extended for an extra two minutes.

#### 5. Tests of fresh SCC

The four standard tests on fresh concrete (L-box Slump flow test, V-funnel test, T50 cm test, and slump flow) were carried out as shown in Figure (5) to ensure that the concrete used to cast the bubbled slabs in this study met the specifications set forward by European federation dedicated to specialist construction chemicals and concrete systems EFNARC [20] of SCC, and the results were compared to the EFNARC standard limitations [20]. The results of these tests meet the EFNARC's standards [17], as shown in Table (3).



**Figure 5.** Self-compacting concrete tests (slump flow, V-funnel and L-box)

**Table 3:** Slump flow, T50, V-funnel, and L-box tests results from SCC

| Mix name                                   | Slump flow (mm) | T50 (sec) | V – funnel (sec) | L – box (H2 / H1) |
|--|-----------------|-----------|------------------|-------------------|
| Normal Strength Self – Compacting Concrete | 760             | 3.5       | 8                | 0.96              |
| High Strength Self – Compacting Concrete   | 720             | 4         | 7.5              | 0.93              |
| Limits of EFNARC [14]                      | 650 – 800       | 2 – 5     | 6 – 12           | 0.8 – 1           |

## 6. Casting and curing

After mixing, the new SCC was placed into the slabs' timber molds. Concrete cylinders were placed with each slab casting to determine the concrete's compressive strength. After 24 hours,

the molds are removed, and the slabs are immersed in water for 28 days, as per ASTM C 192/C 192M-02 (21). Figure (6) depicts the opening of the molds and the filling of the slabs with water.

**Figure 6.** Opening the molds and submerging the slabs in water for curing

## 7. Hardened SCC mechanical properties

The mix's mechanical properties were investigated, and the results are presented in Table (4). The properties had been tested in our

work; splitting tensile strength, and modulus of rupture at 28 days. Each number in the table is the average of the values of three specimen at 28 days.

**Table 4:** The mechanical properties of SCC which has been hardened

| Slab | Compressive strength $f'c$ (MPa) | Splitting tensile strength $f_t$ (MPa) | Modulus of rupture $f_r$ (MPa) |
|------|----------------------------------|--|--------------------------------|
| S1   | 31.5                             | 3.2                                    | 4.6                            |
| S2   | 31.2                             | 3.6                                    | 4.4                            |
| S3   | 31.7                             | 3.4                                    | 4.7                            |
| S4   | 31.3                             | 3.8                                    | 4.1                            |
| S5   | 60.6                             | 6.2                                    | 5.7                            |
| S6   | 60.8                             | 6.8                                    | 5.3                            |
| S7   | 60.1                             | 6.1                                    | 5.9                            |
| S8   | 59.6                             | 6.7                                    | 5.1                            |

## 8. Test setup

All slabs were taken from the curing water tank after 28 days, allowed to dry, and then covered with a white tint to highlight fractures. The machine used in the testing is a universal

hydraulic machine with a capacity of (2000KN) that can be found in Diyala University's College of Engineering's structural Engineering laboratory. Each slab is supported by a square robust steel frame with a circular section of 50

mm diameter that measures (425 x 425 mm) (centre to centre) and serves as a simple support beneath the slabs. To transmit the load produced by a universal hydraulic machine, a rigid steel cylinder with a diameter of 100 mm was placed in the centre of the top face. At each stage of the loading operation, an electrical Linear Variable Displacement Transducer was employed to

measure the vertical deflection (LVDT). The LVDT was mounted in the middle of the slab bottom face and connected to the channel system for continuous data collection. Figure (7) shows the test setup for one of the slabs. The applied load, which was central deflection, was recorded using a data gathering device.



Figure 7. Setup for testing

## 9. Discussion of the results

### 9.1 Failure mode and crack pattern

The first cracks form in the centre of the bottom face early in the loading process, and this is known as the first crack load. As loads increase, radial cracks begin to form from the

slab centre toward the slab edges. At the same time, the fissures become more numerous and wider. Increased stress caused a total failure, and all tested slabs collapsed in flexure due to steel reinforcing yielding. The crack pattern and kind of failure of the slabs that were tested are shown in the Figure (8) and Figure (9).

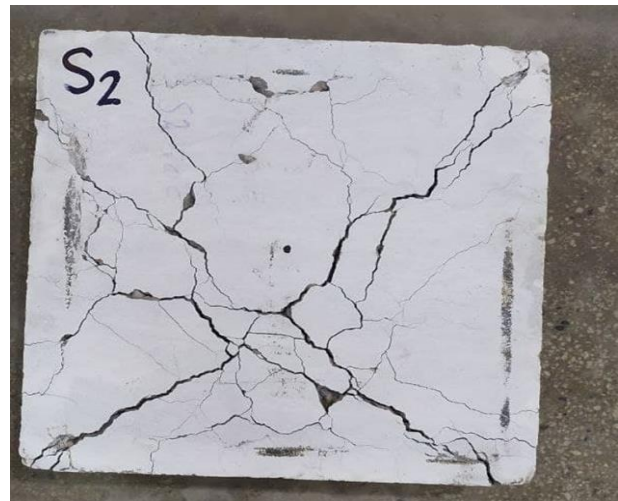





**Figure 8.** The tested slabs' crack pattern and mode of failure group 1

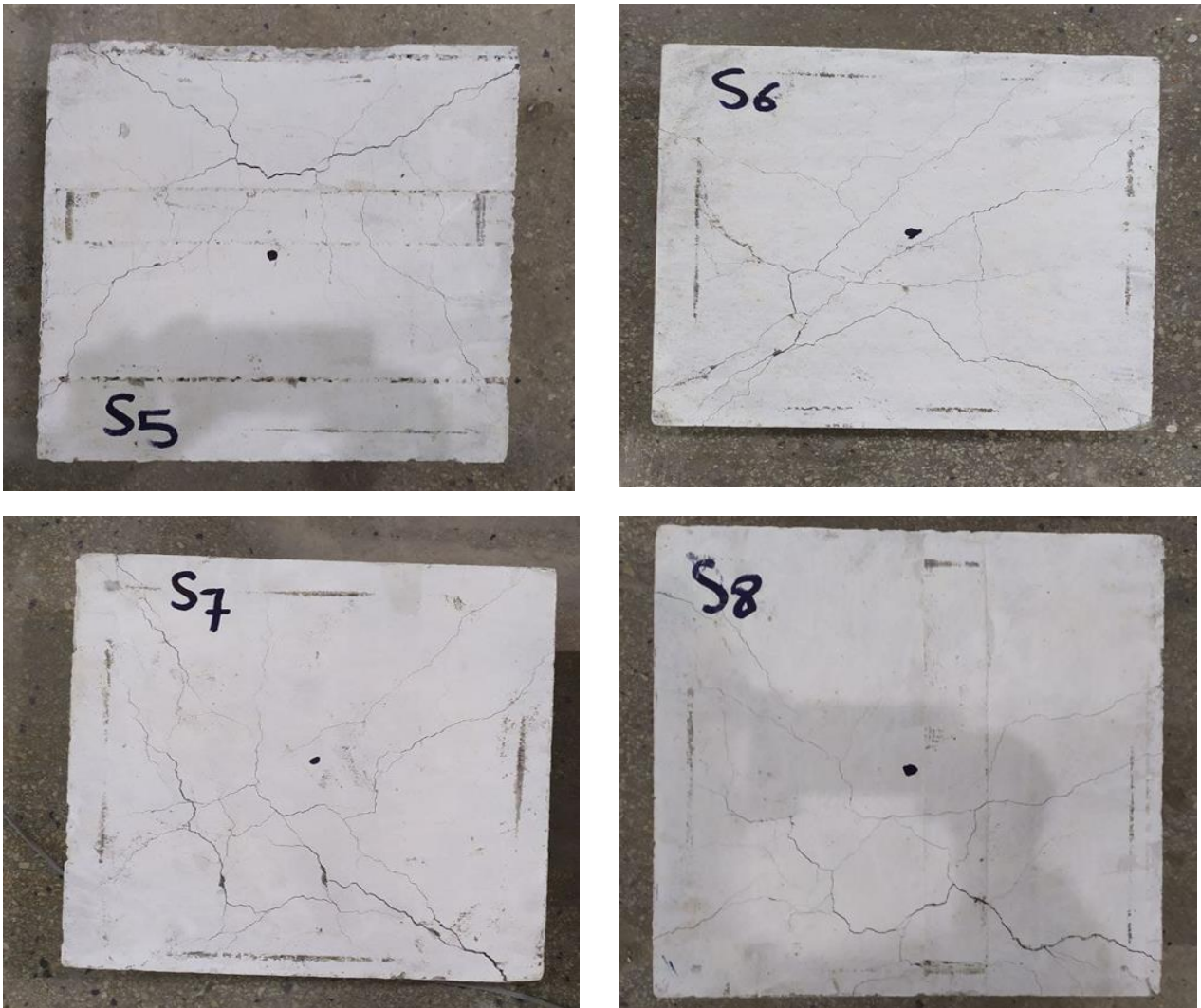

**Figure 9.** The tested slabs' crack pattern and mode of failure group 2

### 9.2 The first crack load

Tables (5) and (6) show the first crack load of the slabs tested. The number of balls has a general effect on the first fracture load: as the number of balls increases, the first crack load decreases.

In comparison to slab S1, the test results in Table (5) revealed that adjusting the N0. of balls for 6x6, 7x7, and 8x8 reduced the first fracture load by 8.3%, 10.6%, and 15.5 %, respectively.

When compared to slab S5, adjusting the N0. of balls for 6x6, 7x7, and 8x8 reduced the first fracture load by 2.5 %, 7.1 %, and 8.92 %, respectively, as indicated in Table (6).

**Table 5:** Shows the first crack load on the slabs

| Slab | No. of Balls | First crack load (kN) | Decreasing percentage (%) |
|------|--------------|-----------------------|---------------------------|
| S1   | 5 x 5        | 26.4                  | -                         |
| S2   | 6 x 6        | 24.2                  | 8.3                       |
| S3   | 7 x 7        | 23.6                  | 10.6                      |
| S4   | 8 x 8        | 22.3                  | 15.5                      |

**Table 6:** Shows the first crack load on the slabs

| Slab | No. of Balls | First crack load (kN) | Decreasing percentage (%) |
|------|--------------|-----------------------|---------------------------|
| S5   | 5 x 5        | 32.5                  | -                         |
| S6   | 6 x 6        | 31.7                  | 2.5                       |
| S7   | 7 x 7        | 30.2                  | 7.1                       |
| S8   | 8 x 8        | 29.6                  | 8.92                      |

### 9.3 The ultimate load

Tables (7) and (8) show the ultimate load of the tested slabs. In general, the influence of the number of balls on the ultimate load is that as the number of balls increases, the ultimate load decreases.

6x6, 7x7, and 8x8 decreased the ultimate load by 3.98 %, 7.53 %, and 12.15 %, respectively.

In comparison to slab S5, changing the number of balls N0. for 6x6, 7x7, and 8x8 reduced the ultimate load by 5.95 %, 10.19 %, and 16.89 %, respectively, as shown in Table (8).

In comparison to slab S1, the test results in Table (8) revealed that changing N0. of balls for

**Table 7:** The slabs' ultimate load results

| Slab | No. of Balls | The ultimate load (kN) | Percentage decreases (%) |
|------|--------------|------------------------|--------------------------|
| S1   | 5 x 5        | 93                     | -                        |
| S2   | 6 x 6        | 89.3                   | 3.98                     |
| S3   | 7 x 7        | 86                     | 7.53                     |
| S4   | 8 x 8        | 81.7                   | 12.15                    |

**Table 8:** The slabs' ultimate load results

| Slab | No. of Balls | Ultimate load (kN) | Decreasing percentage (%) |
|------|--------------|--------------------|---------------------------|
| S5   | 5 x 5        | 134.4              | -                         |
| S6   | 6 x 6        | 126.4              | 5.95                      |
| S7   | 7 x 7        | 120.7              | 10.19                     |
| S8   | 8 x 8        | 111.7              | 16.89                     |

### 9.4 The curve of load deflection

Figures (10) and (11) illustrate the load-deflection of the slabs; it can be seen that the

influence No. of balls of bubbled slabs reduces slab stiffness and increases deflection in all stages of loading when compared to the S1 and S5 slabs.

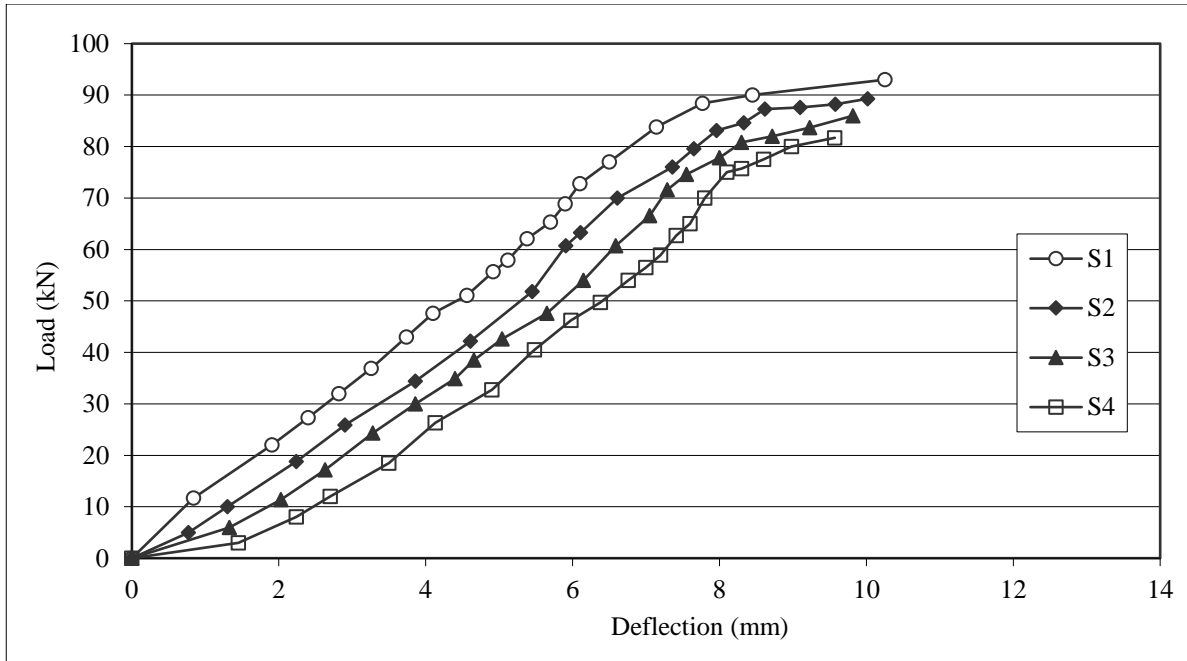

Figure 10. Load-deflection curves for slabs in Group 1

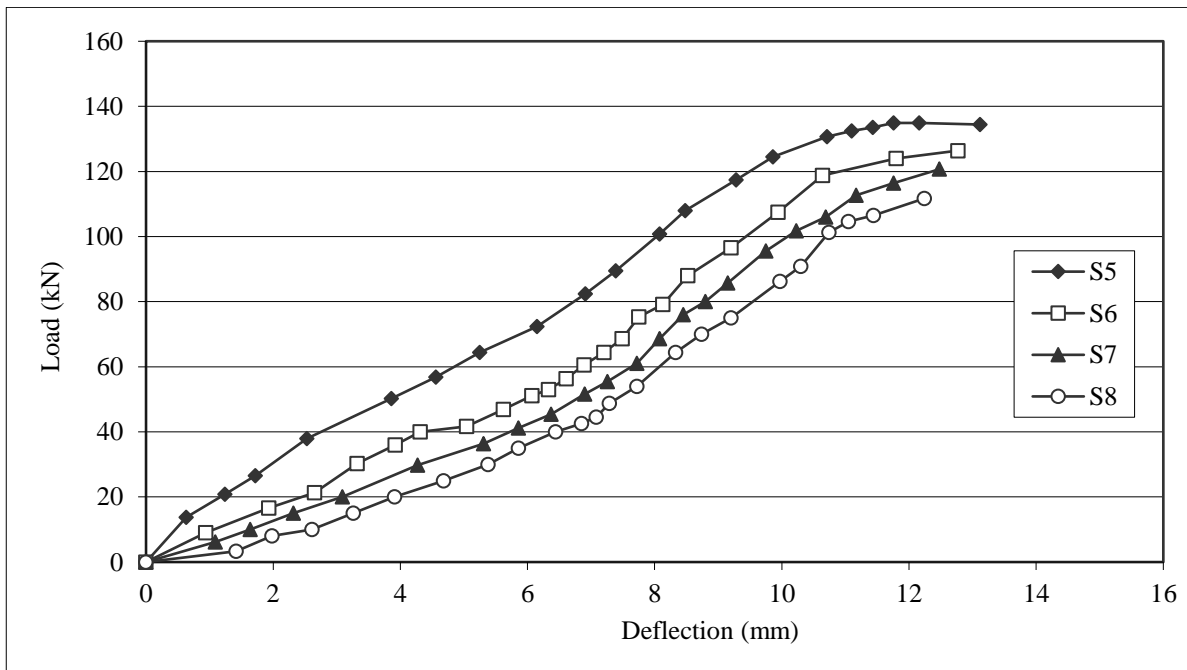

Figure 11. Load-deflection curves for slabs in Group 2

### 9.5 Ultimate deflection

The ultimate deflection of the tested slabs is shown in Tables (9) and (10). In general, the influence of the number of balls on the ultimate deflection is that as the number of balls increases, the ultimate deflection decreases.

In comparison to slab S1, the test findings in Table (9) showed that changing NO. of balls

for 6x6, 7x7, and 8x8 reduced ultimate deflection by 2.34 %, 4.29 %, and 6.73 %, respectively, as compared to slab S1.

However, as shown in Table (10), changing NO. of balls for 6x6, 7x7, and 8x8 caused the ultimate deflection to decrease by 2.67 %, 4.88 %, and 6.71 %, respectively, when compared to slab S5.

**Table 9:** The slabs' ultimate deflection

| Slab | No. of Balls | Ultimate deflection (mm) | Decreasing percentage (%) |
|------|--------------|--------------------------|---------------------------|
| S1   | 5 x 5        | 10.26                    | –                         |
| S2   | 6 x 6        | 10.02                    | 2.34                      |
| S3   | 7 x 7        | 9.82                     | 4.29                      |
| S4   | 8 x 8        | 9.57                     | 6.73                      |

## 10. Conclusion

The effect of the quantity of balls on the flexural behavior of bubbled slabs was investigated experimentally. The results presented include first crack, ultimate load, crack patterns failure mode and load- deflection behavior.

1. When the number of balls was changed from 6x6, 7x7, and 8x8, the first crack load decreased by 8.3%, 10.6%, and 15.5 percent, respectively, as compared to slab S1.
2. Changes in NO. of balls for 6x6, 7x7, and 8x8 resulted in percentage decreases in the first fracture load of 2.5 %, 7.1 %, and 8.92 %, respectively, when compared to slab S5.
3. Changes in NO. of balls for 6x6, 7x7, and 8x8 resulted in percentage decreases in ultimate load of 3.98 %, 7.53%, and 12.15 %, respectively, when compared to slab S1.
4. When the number of balls is changed for 6x6, 7x7, and 8x8, the ultimate load is reduced by 5.95 %, 10.19 %, and 16.89 %, respectively, as compared to slab S5.
5. When the number of balls in the 6x6, 7x7, and 8x8 configurations was altered, the final deflection reduced by 2.34 %, 4.29 %, and 6.73 %, respectively, when compared to slab S1.
6. When changing NO. of balls for 6x6, 7x7, and 8x8, the final deflection decreased by 2.67 %, 4.88 %, and 6.71 %, respectively, when compared to slab S5.
7. In comparison to S1 and S5, changing the number of balls for 6x6, 7x7, and 8x8 lowered slab stiffness.

## References

- [1] Mr. Devyanshu Jain, Miss. Nidhi Gupta." Review Paper: Study on A Comparative Study Ofbubble Deck Slab and Conventional Deck Slab", Department of Civil Engineering, RKDF Institute of Science & Technology (India), Vol. No. 5, Issue No.03, March 2017.
- [2] Al- Azzawiand and Omar." A State Of The Art Review On Reinforced Concrete Voids Slabs",Al-Nahrian University, Baghdad, Iraq, VOL. 13, NO. 5, MARCH 2018.
- [3] "Bubble Deck Engineering Design and Properties Overview". BubbleDeck Voids Flat Slab Solution– Technical Manual and Documents, www.BubbleDeck.com, (2007).
- [4] A.C. Fuchs: "Bubble Deck Floor System - An Innovative Sustainable Floor System". Bubble Deck Netherlands B.V., AD Leiden, the Netherlands, (2009).
- [5] "Lighter Flat Slab Structures with Bubble Deck". Product Information, [www.BubbleDeck-UK.com](http://www.BubbleDeck-UK.com), (2006).
- [6] Bubble Deck, United Kingdom: "Bubble Deck Structure Solutions". www.BubbleDeck-UK.com, (2008).
- [7] Ibrahim A. M., Ali N. K. and Salman W. D. "Flexural capacities of reinforced concrete two-way bubble deck slabs of plastic spherical voids", Diyala Journal of Engineering Sciences, ISSN 1999-8716, Vol. 06, No. 02, June 2013.
- [8] Yaseen, D. "Serviceability and Load Capacity of One-Way Prestressed Concrete Slabs with Internal Spherical Voids", Ph.D. Thesis, University of Baghdad, 2014.
- [9] Ahmed Q. W. "Punching Shear Behavior Of Bubbled Reinforced Concrete Slabs", Diyala Journal of Engineering Sciences, ISSN 1999-8716, Vol. 09, No. 01, pp. 55-66, March 2016.
- [10] Mutashar S. H. " Flexural Behavior of Sustainable Reactive Powder Concrete Voids Slabs", M.Sc. Thesis, College of Engineering, Al-Mustansiriayah University, February 2017.
- [11] Mahmood M. R. K. and Dawood M. B. "Punching Shear Behavior of Continuous Bubbled Reinforced Reactive Powder Concrete Slab", Journal of Babylon University/Engineering Sciences/No. (1)/Vol. (25), 2017.
- [12] Harba, I. S. I. and Hameed, M. A. "Shear Behavior of Self Compacted Reinforced Concrete Two Way

- Bubble Slabs", International Journal of Civil Engineering and Technology (IJCIET), Volume 9, Issue 12, December 2018, pp. 1117–1127.
- [13] Ibrahim A. M., Ismael M. A. and Abdul Hussein H. A. S. " The Effect of Balls Shapes and Spacing on Structural Behaviour of Reinforced Concrete Bubbled Slabs", Journal of Engineering and Sustainable Development, Vol. 23, No.02, March 2019 ISSN 2520-0917.
- [14] Yaagoob A. H. and Harba I. S. I. "Behavior of Self Compacting Reinforced Concrete One Way Bubble Deck Slab", Al-Nahrain Journal for Engineering Sciences NJES 23(1)1-11, 2020.
- [15] (15) Iraqi Specification, No. 5/1984,"Portland Cement", Ministry of Planning /Central Organization for Standardization and Control Quality.
- [16] Iraqi Specification, No. 45/1984"Aggregate from Natural Sources for Concrete and Construction. Ministry of Planning /Central Organization for Standardization and Control Quality.
- [17] Ramachandran, V.S., "Concrete Admixtures Handbook-Properties, Science, and Technology", 2<sup>nd</sup> Edition, William Andrew Publishing, ISBN-8155-1373-9,1995, p. 121.
- [18] ASTM C494M-1999a, "Standard specification for Chemical Admixtures for Concrete", Vol. 4.2,1999, p.9.
- [19] ASTM A615/615M-05a, " standard specification for Deformed and Plain Carbon Structural Steel Bars for Concrete Reinforcement", Annual book of ASTM standards, Vol.01.02,2005.
- [20] EFNARC: European Federation Dedicated to Specialist Construction Chemicals and Concrete Systems, "Specifications and Guidelines for Self-Compacting concrete", Association House, 99 west street, Farnham, Surrey, U.K, 2002, 32p.
- [21] ASTM C 192/C 192M-02. (2002) Standard Practice for Making and Curing Concrete Test Specimens in the Laboratory. ASTM Standard.