

Simulation two storey house of masonry wall under the earthquake load

Ali Laftah. Abbas, Maan. H. Saeed

Department of Civil Engineering, College of Engineering, University of Diyala
dylatophousing@yahoo.com

Abstract

The masonry wall building systems have high sensitivity against earthquakes and the fact that this system of construction is widespread in Iraq, especially condominiums. Iraq subjected to many earthquakes in recent years and is expected to be subjected to more intensities of earthquakes in the future engendered an urgent need to investigate the behavior of this type of construction under the influence of earthquakes. The analysis of two-storey house in this research paper was performed by the finite element package program ABAQUS. Model simulation with dimensions (5 * 20 m) from the common one and two-storey house models in Iraq. The compressive strength of bricks (17MPa) type A and compressive strength of mortar (15MPa) with mixing ratio 1:3 was used to represent the properties of construction materials in Iraq. The nonlinearity behavior of the materials is considered in this research paper. The model is subjected to PGA(0.5g) from EL-Centro Earthquake (1940 N-S) as input ground motion to determine its seismic performance compared the maximum displacement, drift and base shear for models with the seismic demand of Iraq. Through the analysis of the results, the models proved efficient and stable against the effect of earthquakes, especially when the load applied in the Z long direction, more than the load applied in the X short direction for all models. **Keywords:** Masonry wall, Finite element, Nonlinearity, Earthquake.

Paper History: (Received:29/10/2017; Accepted: 2/1/2018)

Introduction

The masonry building is the oldest types of building systems used in the world, it was used by the ancient Iraqis, Egyptians and Greeks were the stars of urban development of these premises and its reliability and good qualities still compete with modern systems such as concrete and steel[1].The masonry is the public word used to describe the system of construction consists of the unit and bind material. The unit may be brick, block, stone, etc. The binding material may be sand and cement, lime, soil. In this paper considering masonry as brick and mortar (sand and cement 1:3). The main feature of masonry is that it has a good compressive

strength. Its main function is to withstand the gravity loads, including the dead loads and the living loads, but the bricks have a very low tensile strength that shows weakness and sensitivity to lateral loads such as the earthquakes and the wind[2]. There are many ways to numerical representation the masonry wall, despite the complexity of the components of the masonry wall, Where researchers adopted three types of representation micro, simplified, macro modeling as shown in figure (1). The methods of representation depend on the specificity or type of research problem since small(micro) and simplified modeling need to test the components of the masonry wall, such as bricks, mortar or macro modeling, they need to test small wall models to obtain its nonlinear properties[3]. These properties are used to build a model of finite element method using the ABAQUS(6-13) program. The main objective of this paper is to represent the masonry using macro modeling technique to analysis and simulation of masonry building against the impact of earthquakes. This type of modeling is the most valuable technique when applications large scale model and balance between accuracy and cost .

1. Modeling method for brick masonry wall

Several methods have been used to represent the masonry wall and determine the type of representation according to the complexity levels of the problem and the size of the model as well as the type of problem requirements. The representation techniques can be described as follows [2].

1- Micro-modiling: It means complex modeling where both the blocks and the joint of mortar are represented by a separate element with an interface element for the purpose of linking the two elements together. This modeling is often used for small models because of the complexity of the details and the need for more variables than the other types as well as taking a lot of time for representation and analysis, but gives more accurate and reliable results and used when the need to study cracks and failures and stresses as shown in Figure (1-b) [3].

2- Simplified micro-modeling: In this approach, brick is modeled as by continuum element, but is the mortar joint and its interface is with brick is modeled together in an interface

elements. However in this instance the mortar is not defined as a solid element but rather as an interface between the solid brick elements. These interface element represent the preferential crack locations where shear and tensile cracking occurs [2] as shown in Figure (1c).

3- Macro modeling: This type of modeling is the most common and especially in large models, where both the bricks and the mortar are modeled for one piece that possesses part of the properties of

the bricks and the mortar in one. The material properties are introduced through mathematical equations whose variables are the compressive strength of both materials found by researchers or Through the experimental test of brick and mortar samples. This technique is used when there is a need to reduce the time of analysis or the breakdown of storage memory and large size model[2] as shown in Figure (1d).

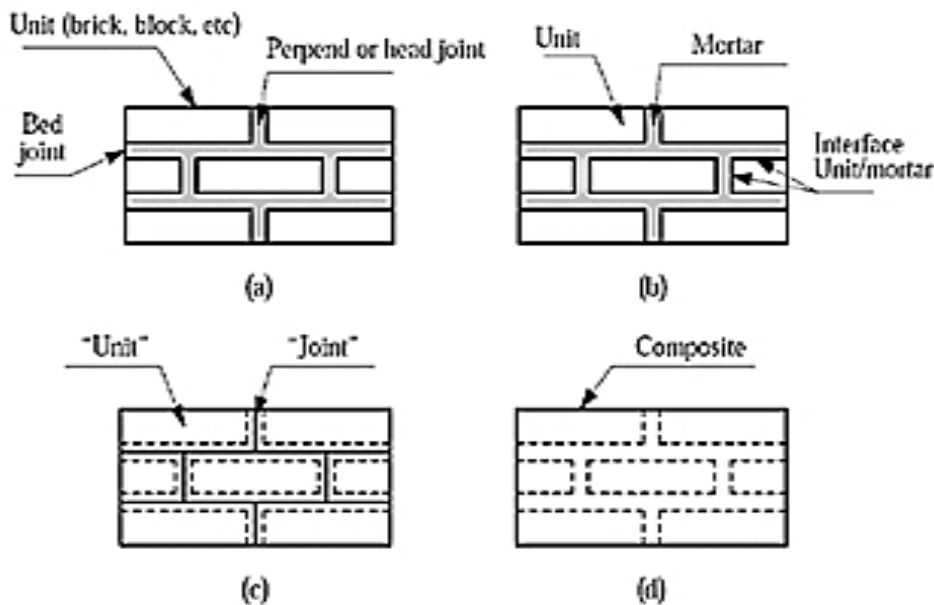

Figure 1 Modeling method for brick masonry wall: a) masonry sample, b) micro modeling, c) simplified micro- modeling, d) macro modeling [3]

2. Material properties

Masonry is usually is non - elastic, heterogeneous and anisotropic material, consists of unit construction and bond material where possess different properties completely .Masonry has Compressive strength much higher than its tensile or flexural strength. There for, masonry is used for structures under a compressive load and the bearing capacity of masonry is described generally by the parameter compressive strength (f_m). Taking into account The compressive strength of the bricks f_b is higher than the compressive strength of the mortar f_j , the compressive strength of masonry can be seen as a relationship or a function of the bricks strength and mortar strength. The compressive strength of a masonry prism f_m was calculated from Eq. (1)[4].

$$f_m = K \cdot f_b^\alpha \cdot f_j^\beta \tag{1}$$

where $K=0.36$, $\alpha=0.49$ and $\beta =0.32$ are constants. In eq. (1), α must be higher than β because f_m is found to depend more upon the strength of bricks used in masonry.

f_m = Ultimate compressive strength of a masonry prism in (MPa) .

f_b = Ultimate compressive strength of brick in (MPa).

f_j = Ultimate compressive strength of mortar in (MPa).

The equation (1) just valid for compressive loads perpendicular to the horizontal joints. When the compressive load is applied in the direction of horizontal joints, the strength must be reduced as a result of the influence of the vertical joints was calculated from Eq. (2).

$$\hat{f}_m = 0.75 f_m \tag{2}$$

Modulus of elasticity E_m of masonry prism is calculated from Eq (3) it can be calculated from the compressive strength of a masonry prism f_m [4].

$$E_m = 550 f_m \tag{3}$$

The tensile strength of masonry f_t of masonry prism is calculated from Eq (4). It can be

calculated from the compressive strength of a masonry prism f_m [4].

$$f_t = 0.026 f_m \tag{4}$$

The properties of the materials are explained in Table (1).

Table (1): Material properties

Masonry	Compressive Strength of brick f_{bv} MPa	16.516
	Compressive Strength of brick f_j MP	14.53
	Compressive Strength of masonry prism f_{mv} MPa	4.0173
	Modulus of elasticity E_m MPa	2209.5
	Tensile strength f_t MPa	0.105
	Poisson's ratio ν	0.18
	Density γ kg/m ³	2150
Concrete	Compressive Strength of concrete f_c MPa	25
	Modulus of elasticity E_c MPa	29000
	Tensile strength f_{tc} MPa	2.25
	Poisson's ratio ν	0.2
	Density γ kg/m ³	2400
Steel	Yield stress f_s MPa	400
	Modulus of elasticity E_s MPa	210000
	Poisson's ratio ν	0.3

3. Masonry Wall Represented in ABAQUS

ABAQUS program is a set of programming tools and commands used to build and analyze models depending on the finite element method. ABAQUS contains a large library of elements that enable the user to represent models in various disciplines as well as represent the linear, nonlinear, static, dynamic, heat transfer, fluid flow, and electromagnetic analysis, so it is a general and comprehensive program of all specialties used throughout the world [5].

a) Concrete damage plasticity

Masonry , concrete and steel are materials used to represent the physical properties of the model. A set of properties that need to be defined as inputs such as density, modulus of elasticity and plastic properties to represent masonry ,concrete and steel. The concrete damage plasticity (CDP) model has the ability to generate nonlinear properties of brittle materials such as concrete. concrete and masonry are a brittle material with very low tensile strength. Therefore, CDP model used to generate nonlinear properties of concrete and masonry as shown in figure (2) [6][7]

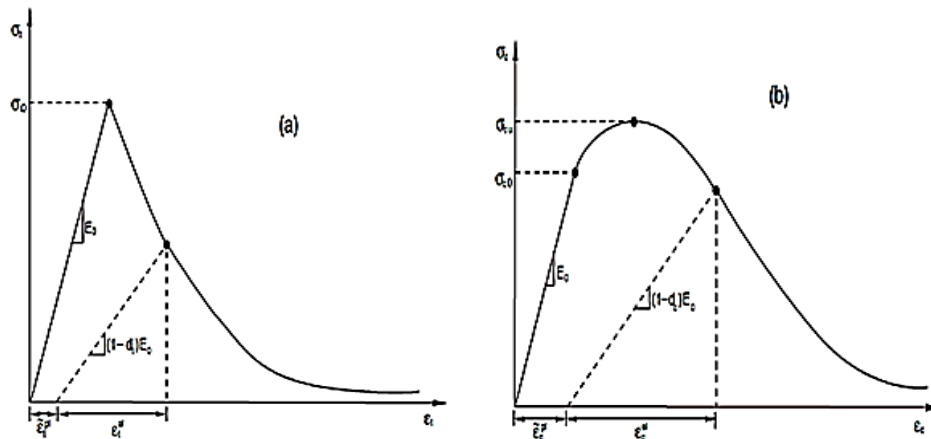

Figure 2 Concrete damage plasticity (CDP) behavior(a)tension, (b)compression

b) C3D8R brick element

The three-dimensional C3D8R brick reduced integration element is used to represent masonry walls, reinforced concrete slab, brick and mortar in the models. This element has the capability of representing large deformation, geometric and crushing in compressive and cracking in tension. It is defined by 8 nodes, each node has three translational degrees of freedom X1, Y2, and Z3 directions as showed in figure (3a).

c) T3D2 truss element

When loading of the slender member on the center line or along it, it has selected the truss element (T3D2) that supports this type of loading for 3D or 2D modeling as shown in figure (3b). The truss element (T3D2) two noded in this study is used to represent the reinforcing steel of the roof, slab, and lintels. [6]

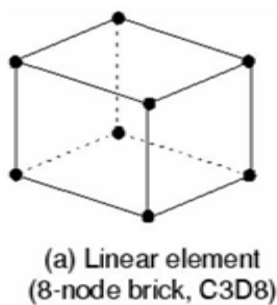

a

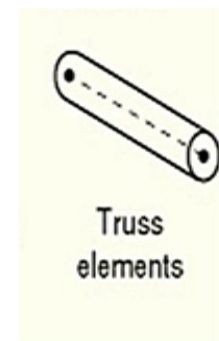

b

Figure 3 a) C3D8R brick element & b) T3D2 truss element

d) Constraints & Interface

Many types of connection in order to be able to properly describe the contact between bodies (FE meshes). For each case, a privacy connection should be taken into consideration. Tie constraint is used to connect different model parts with the same material properties. Embedded for the purpose of

the representation of the concrete reinforced by the ABAQUS program requires the representation of submerging the reinforcing steel inside the concrete and defining the connection between them. Interface elements there are two ways to represent Interface elements in the ABAQUS The first representation of the interface elements as shell

elements and the second representation as a way of product linking between the solid units, In both cases it is need a set of parameters as tangential behavior, normal behavior, cohesive behavior and damage criterion[5].

5-Dynamic load (time history)

The modal analysis is used to evaluate the seismic performance and calculate the maximum displacement and the drift of masonry structures. The time history analysis method is adopted in this study. A time history analysis entails subjecting an

FE model of a structure to the ground acceleration records of an earthquake. It is the important method in the design of a structure for dynamic loading conditions. earthquake El Centro was used in this study, El Centro 1940 with a magnitude of $M_w=5.4$ and peak ground acceleration $PGA=3.5$ (350 cm/sec) as shown in Figure(4), The North-South component is the one chosen because it has the highest peak accelerations. The seismic intensity of the earthquake is adopted as 0.5g according short-period design response acceleration for zone of Iraq.

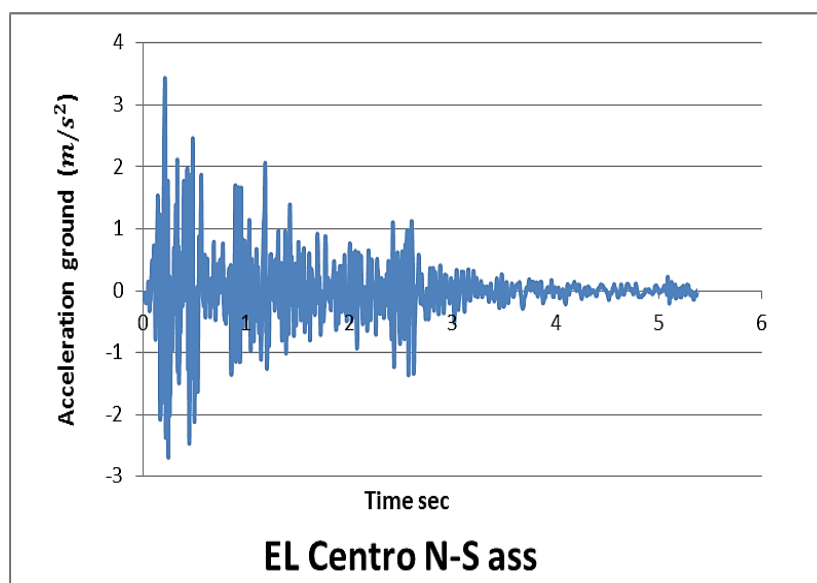

Figure (4) North-South acceleration component of the El Centro 1940

6-Finite Element model

ABAQUS 6.13 program was used to develop finite element model of masonry one storey and two storey have 5 m width and 20 m length plan. The house's detail of internal dimensions, places to install windows and doors openings explain as shown in Figure (5). The dimensions opening in the wall are 2.1 m height, 1m width for doors and 1.5 m height and 2 m width for windows. The height of storey is 3 m and the thickness of masonry wall are 0.24m and 0.18m for reinforced concrete slab. The thickness of continuous reinforced concrete lintel is

0.24 m and 0.3 m depth placed above the openings (doors and windows). The masonry walls are built of clay brick and sand cement mortar. The number of element is 16715, the number of Nods is 23532 and the weight of the model is 144.246 tons of one storey. The number of element is 33430, the number of Nods is 47064 and the weight of the model is 288.851 tons of two storey. El Centro $M_w=5.4$ is subjected as dynamic load in two independent perpendiculars (X- direction and Z- direction). The finite element model of masonry one storey and two storey models shown in Figure (6).

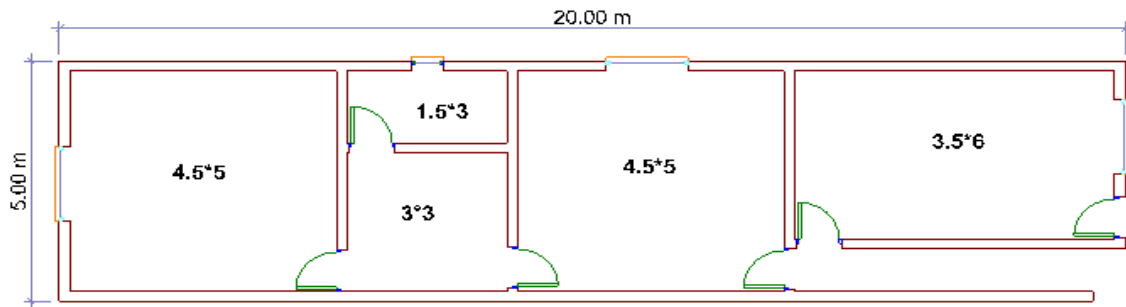
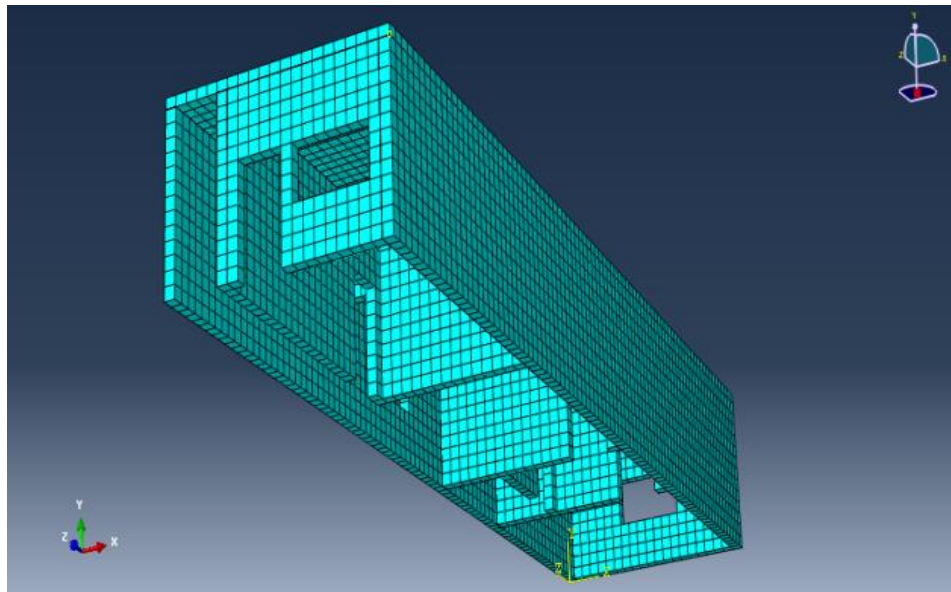
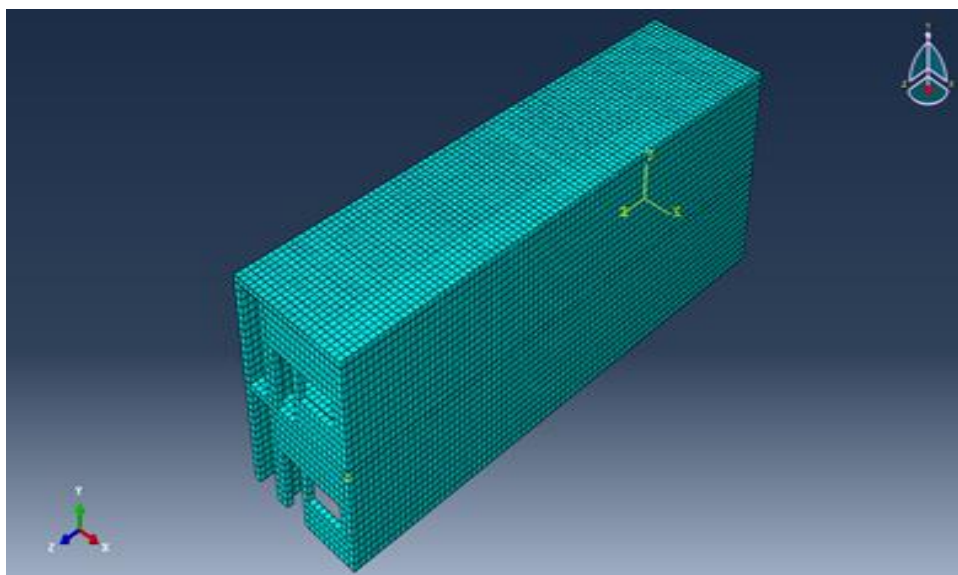

Figure (5) house of 5m*20m plan.



One storey



Two storey

Figure (6) Finite element idealization of masonry house

7-Results and discussion

The results dynamic analysis of El Centro earthquake in final deformation pattern for one storey and two storey are explained as shown in Figure (7,8). The maximum displacement curves of one storey and two storey model are explained in Figure (9,10).The story drift curves of one storey and two storey model are explained in Figure (11,12). While the dynamic analysis results and seismic demands (demand base shear and story drift limit) are explained in Tables (2) according to the

preliminary draft of Iraqi code[9] and ASCE Standard ASCE/SEI 7-10[8]. The results analysis of one storey shows that when the dynamic load(El Centro earthquake) applied in X- direction, the maximum displacement increased by 14.54% for when the dynamic load applied in Z- direction. Like that, when dynamic load applied in X- direction the storey drift increased by 37.6% for when dynamic load applied in Z-direction. While, when the dynamic load applied in Z- direction the ultimate base shear capacity have increased by 16.8% for when the dynamic load applied in X- direction.

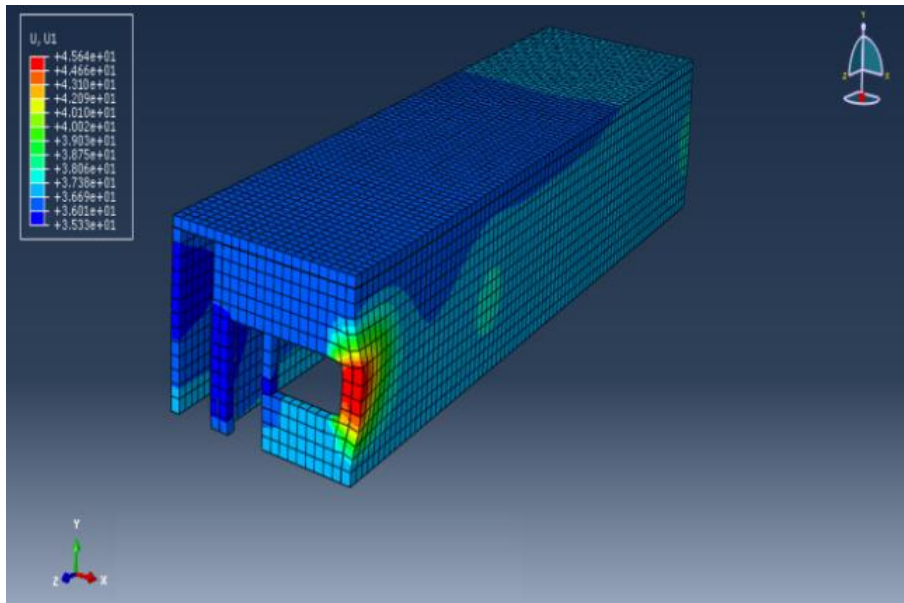

(a)X-Direction

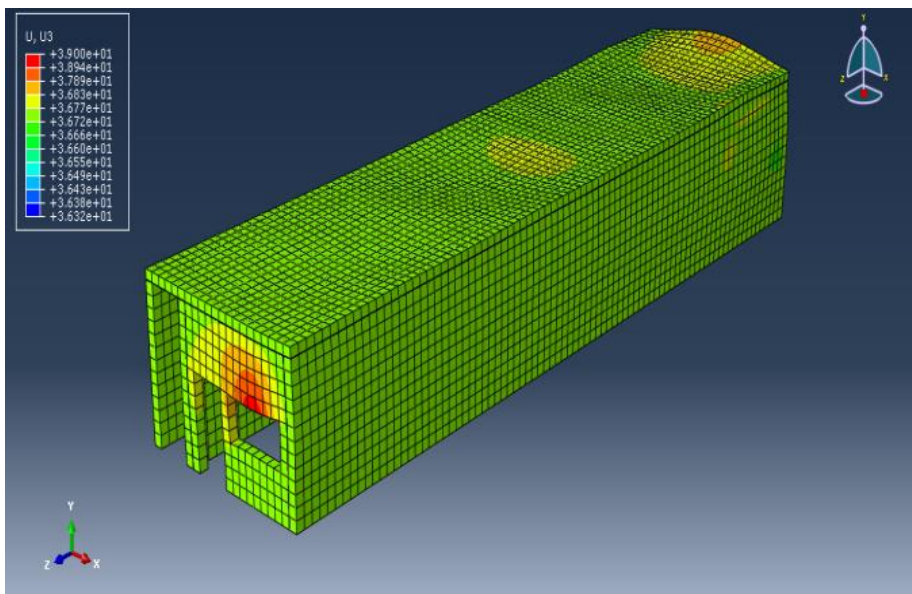

(b) Z-Direction

Figure 7 Deformation shapes of one storey for El Centro earthquake Mw=5.4.

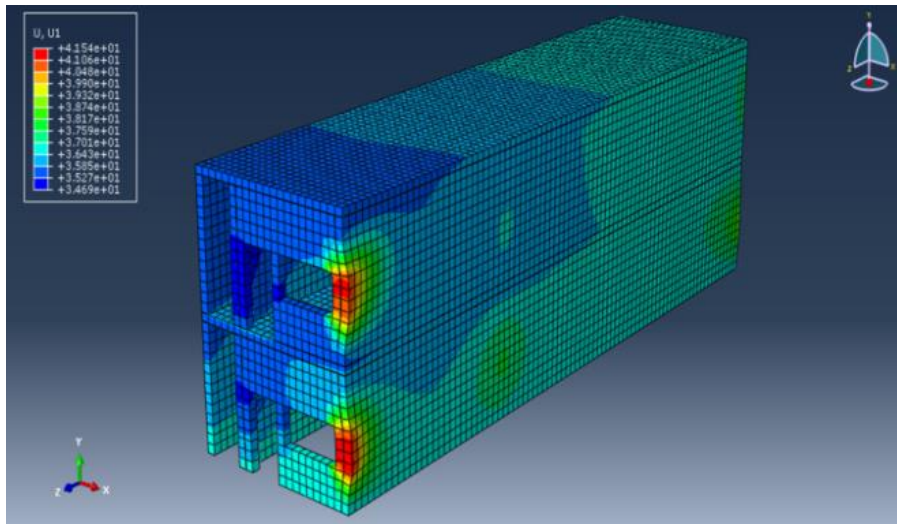

(a)X-Direction

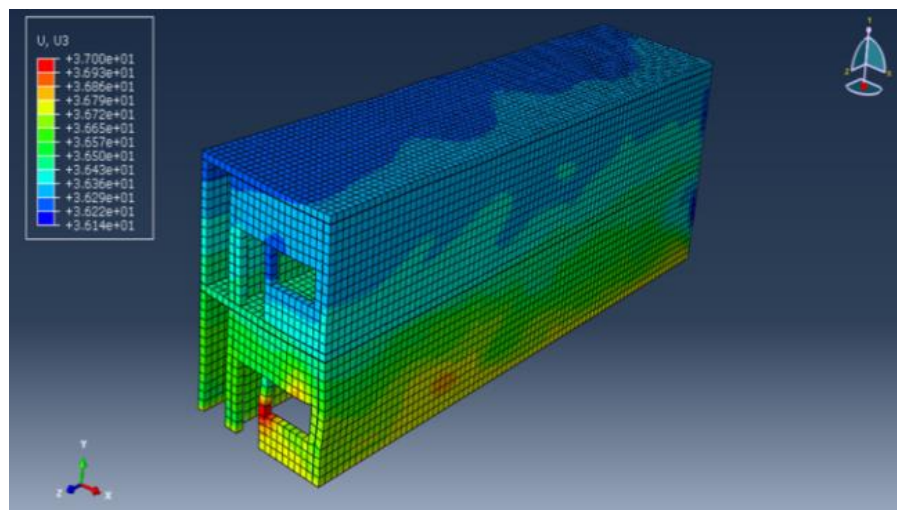

(b) Z-Direction

Figure 8 Deformation shapes of two storey for El Centro earthquake Mw=5.4.

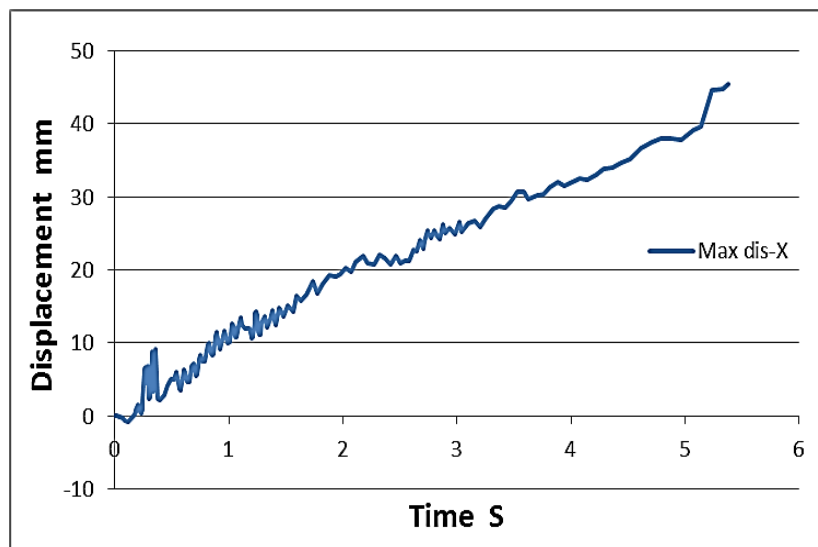

(a)X-Direction El Centro

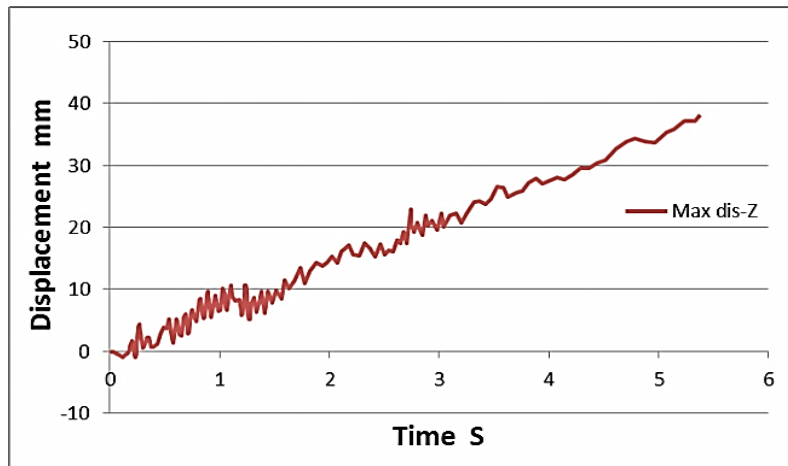

(b) Z-Direction El Centro

Figure (9) The maximum displacement curves of one storey

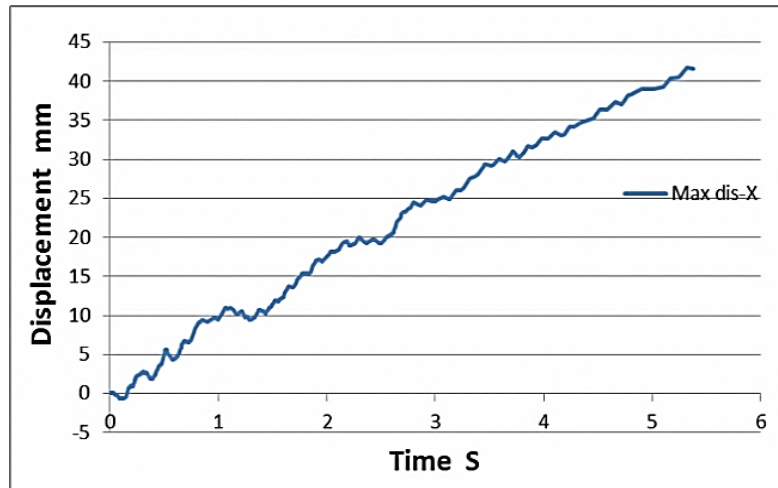

(a) X-Direction El Centro

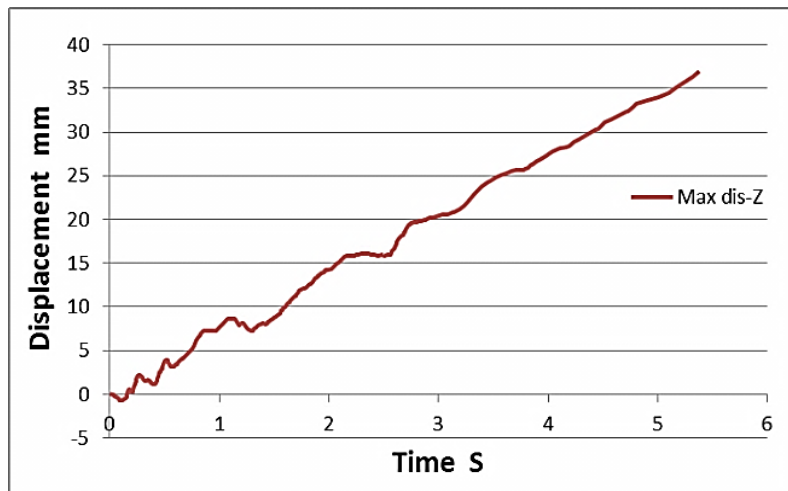

(b) Z-Direction El Centro

Figure 10 The maximum displacement curves of two storey

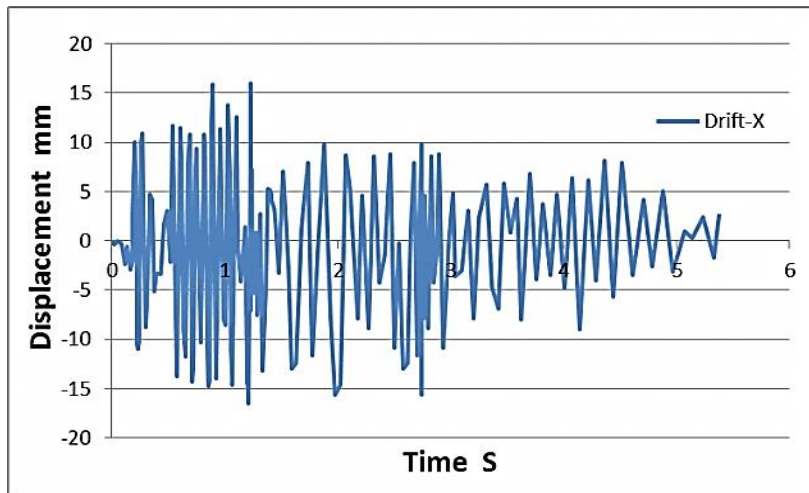

(a) X-Direction El Centro

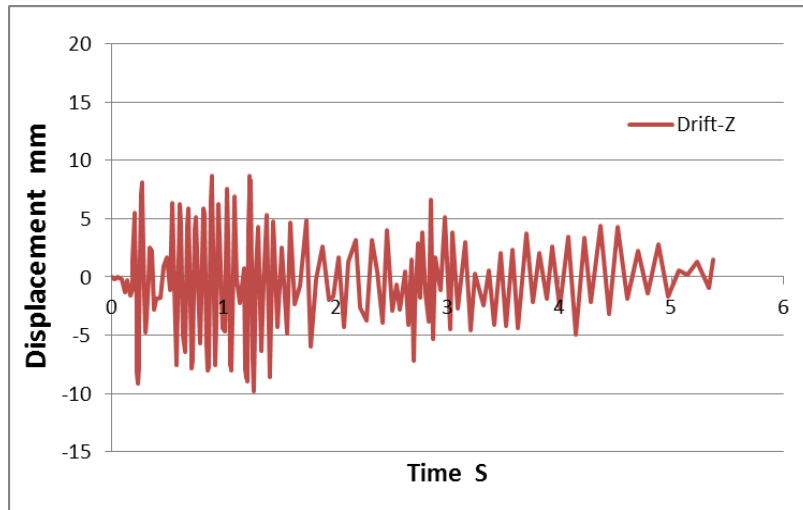

(b) Z-Direction El Centro

Figure 11 The storey drift curves of the one storey

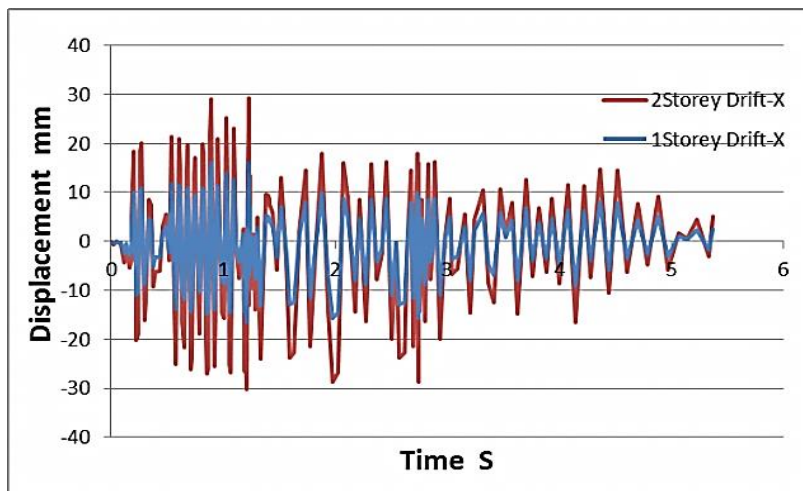

(a) X-Direction El Centro

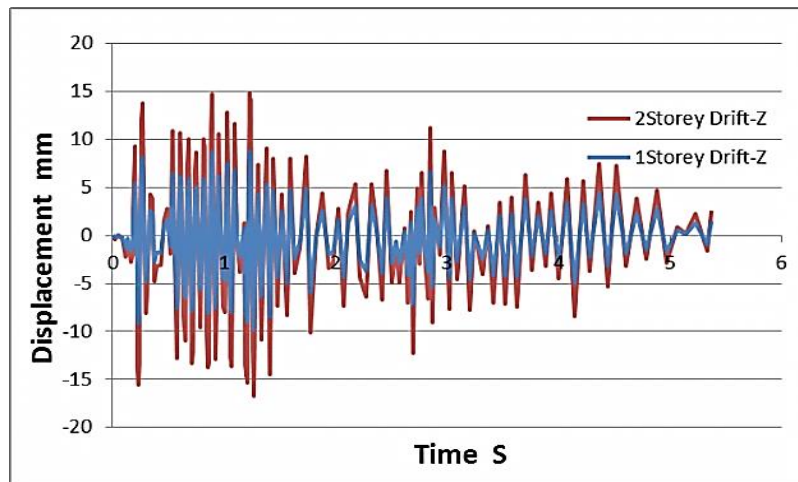

(b) Z-Direction El Centro

Table 2 Ultimate capacity of the one storey and two storey model versus seismic demand

	Direction	Maximum displacement mm	Target drift mm	Drift mm	Demand base shear kN	Ultimate base shear kN	Evaluation
One storey	X-Direction	45.64	31.8	7.32	977	790	Stable
	Z-Direction	39.0	31.8	7.25	977	950	Stable
Two storey	X-Direction	41.54	63.6	13.23	1954	1560	Stable
	Z-Direction	37	63.6	13.12	1954	1940	Stable

The results analysis of two storey shows that when the dynamic load(El Centro earthquake) applied in X- direction, the maximum displacement increased by 10.93% for when the dynamic load applied in Z- direction. Like that, when dynamic load applied in X- direction the storey drift increased by 40.3%for when dynamic

load applied in Z-direction. While, when the dynamic load applied in Z- direction the ultimate base shear capacity have increased by 19.58% for when the dynamic load applied in X- direction.

Consequently ,it was observed the discrepancy between the displacement, drift and base shear in the direction of X-direction and the Z-direction, where the increased displacement of X-direction is by10-14.5% of Z-direction, increase drift of X-direction by 35-40% of Z-direction and the increase base shear of Z-direction by 16-20% of X-direction . This disparity is due to the thinnest dimensions in X- direction. As for total displacement, noticing a decrease in the displacement value in the two-storey model due to the increase in the mass of the model.

8-Conclusions

This study evaluates the seismic performance of this type of houses spread in Iraq and proved

effective against earthquakes in comparison with the seismic demand according to the preliminary draft of Iraqi code and ASCE Standard ASCE/SEI 7-10[6]. The macro modeling representation and the ABAQUS program proved effective in representing the model and the nonlinear properties of the material. The results indicate that there is a discrepancy between the amount of maximum displacement in the direction of X than the direction of Y and the same behavior for the drift. This discrepancy is attributed to the thin of the shape and the impact of dynamic load on it and also shows that the longitudinal walls provide better performance when the subjected of the load in-plane walls more than is out-of-plane to resisting the dynamic load.

Acknowledgment

This work was supported by University of Diyala, Department of Civil Engineering, which is gratefully acknowledged.

References:

[1] Alexander Costa "Experimental testing of lateral capacity of masonry Piers.AN application to seismic assessment of AAC

- masonry building" M.SC. Thesis, University degli Studi di Pavia, 2007
- [2] Lourenco, P. B. "Computational Strategies for Masonry Structures", Ph.D. Thesis, Delft University, the Netherlands, (1996a).
- [3] Gsmagl Ozan Demgrel, "A nonlinear Equivalent Frame Model for Displacement Based Analysis of Unreinforced Brick Masonry Buildings" M.SC. Thesis, Middle East technical university, 2010.
- [4] Hemant B. Kaushik; Durgesh C. Rai ; and Sudhir K. Jain, M.ASCE," Stress-Strain Characteristics of Clay Brick Masonry under Uniaxial Compression", Journal of Materials in Civil Engineering, Vol. 19, No. 9, September 1, 2007.
- [5] Abaqus Analysis User's Manual. Vol. 1-5, SIMULA,2009.
- [6] A. Joshua Daniel and R.N. Dubey," Finite Element Simulation Of Brick Masonry Building Under Shock Loading", Tenth U.S. National Conference on Earthquake Engineering Frontiers of Earthquake Engineering July 21-25, 2014.
- [7] Mohammad Bolhassani a,†, Ahmad A. Hamid a, Alan C.W. Lau b, Franklin Moona," Simplified micro modeling of partially grouted masonry assemblages", Elsevier Science & Technology, Construction and Building Materials 83 (2015) 159–173.
- [8] Minimum design loads for buildings and other structures, "ASCE Standard ASCE/SEI 7-10", Published by American Society of Civil Engineers, Reston, Virginia 2019, TH851.M56, 2010.
- [9] مسودة الاولى لمدونة العراقية" المكتب الاستشاري الجامعة المستنصرية
2013